

This Manual is a FREE Download  
[www.allotment-garden.org](http://www.allotment-garden.org)

## Throttle Lever

Remove the throttle lever and spring and file off the peened end of the throttle shaft until the lever can be removed. Install the throttle spring and lever on the new carburetor with the self-tapping screw furnished. If dust seals are furnished, install them under the return spring.

## Idle Speed Adjustment Screw

Remove the screw assembly from the original carburetor and install it in the new carburetor. Turn it in until it contacts the throttle lever. Then an additional 1-1/2 turns for a static setting.

## Final Checks

Consult the service section under "Pre-sets and Adjustments" and follow the adjustment procedures before placing the carburetor on the engine.

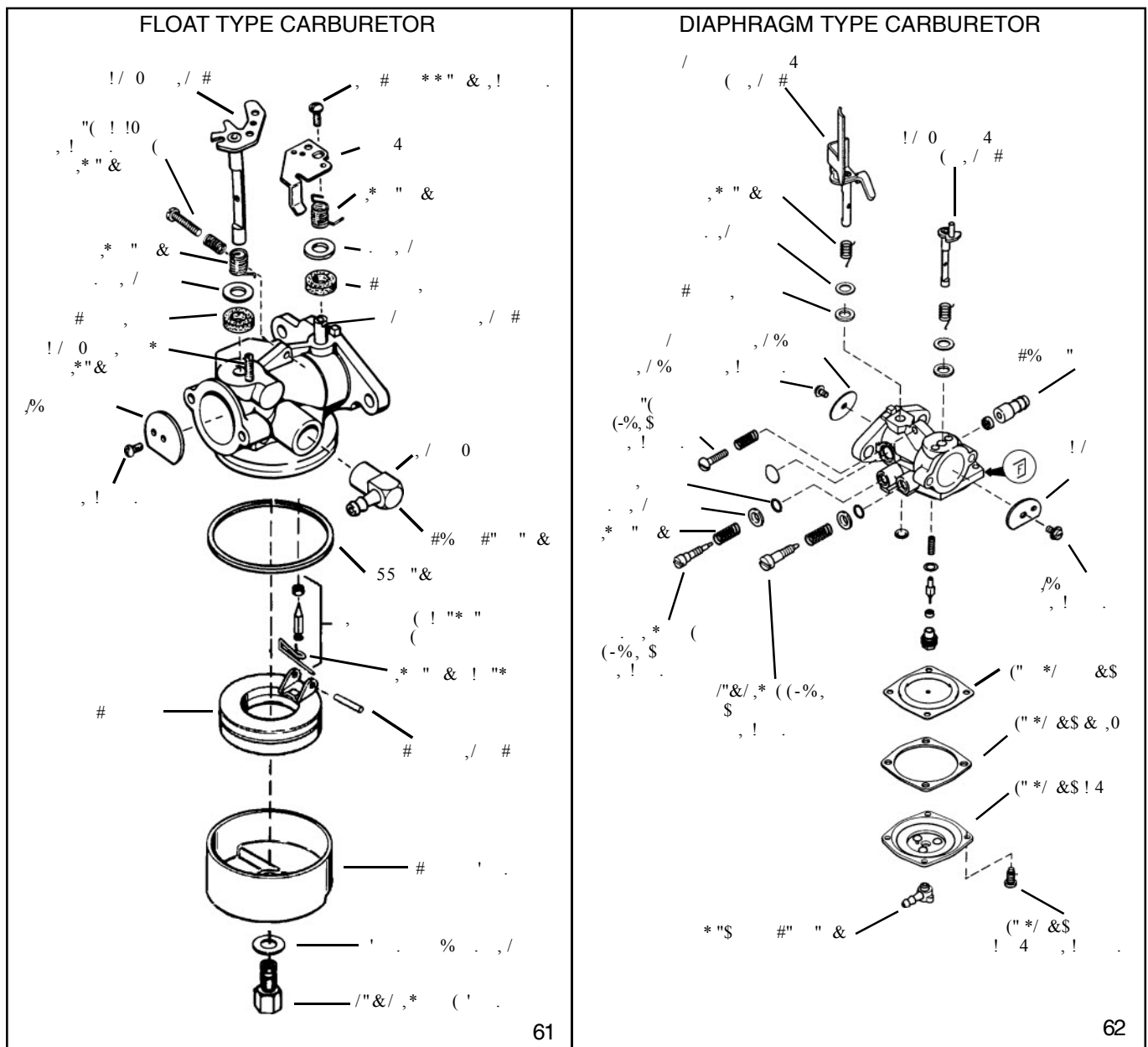

# CHAPTER 4 GOVERNORS AND LINKAGE

## GENERAL INFORMATION

This chapter includes governor assembly and linkage illustrations to aid in governor or speed control assembly.

Tecumseh 4 cycle engines are equipped with mechanical type governors. The governor's function is to maintain a constant R.P.M. setting when engine loads are added or taken away. Mechanical type governors are driven off the engine's camshaft gear. Changes in engine R.P.M. cause the governor to move the solid link that is connected from the governor lever to the throttle in the carburetor. The throttle is opened when the engine R.P.M. drops and closes as the engine load is removed.

## OPERATION

As the speed of the engine increases, the governor weights (on the governor gear) move outward by centrifugal force. The shape of the governor weights force the governor spool to lift. The governor rod maintains contact with the governor spool due to the governor spring tension. As the spool rises, the governor rod rotates, causing the attached outer governor lever to pull the solid link and close the opening. When the engine speed decreases, the lower centrifugal force allows the governor weights to be pulled in by the governor spring. As the spool lowers, the rod rotates and the solid link pushes the throttle to a more open position (diag. 1).

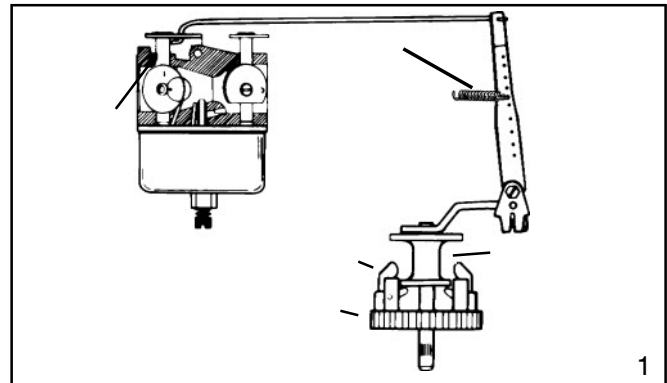

## INTERNAL COMPONENTS (VARIOUS STYLES)

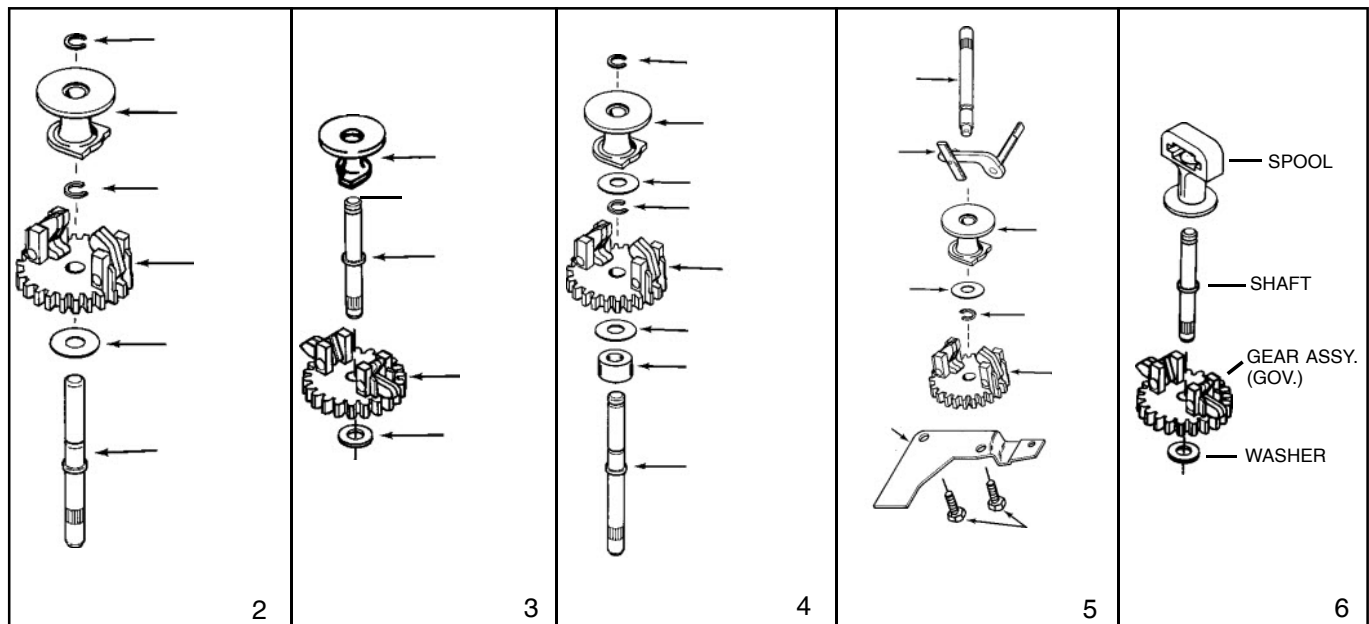

## TROUBLESHOOTING

Engine problems where the governor is suspected to be the cause, may actually be the result of other engine system problems. Hunting (engine R.P.M. surging up and down) indicates that the engine is incapable of maintaining a constant R.P.M. with or without an engine load. Engine overspeeding (either with or without throttle movement) must immediately before serious engine damage occurs. Use the following procedure to diagnose a suspected governor problems.

## ENGINE OVERSPEEDING

1. If the engine runs wide open (faster than normal), shut the engine **immediately**.
2. Check the condition of the external governor shaft, linkage, governor spring, and speed control assembly for breakage, stretching or binding. Correct or replace binding or damaged parts.
3. Follow the governor adjustment procedure and reset the governor - see "Service" in this chapter.
4. Run the engine. Be ready to shut the engine off if an overspeed problem still exists. If the problem persists, the engine will require disassembly to inspect the governor gear assembly for damage, binding, or wear.
5. See Chapter 9 under "Disassembly Procedure" to disassemble the engine.
6. Remove the governor gear assembly. Repair or replace as necessary.

## ENGINE SURGING

1. Try to stabilize the engine R.P.M. by holding steady the solid link between the governor arm and the carburetor throttle, using a pliers or fingers.
2. If the engine R.P.M. stabilizes, the governor or governor adjustment should be checked. See "Service" governor adjustment procedure in this chapter. If the engine R.P.M. does not stabilize, the engine will require additional checks, see Chapter 9 under "Troubleshooting".
3. If the problem persists after the governor adjustment, check the engine R.P.M. found on microfiche card # 30. The R.P.M. settings are critical. If the R.P.M. setting for high and low speed are within specification and a slight surge is experienced, increasing the engine idle R.P.M. setting slightly may eliminate this condition.
4. Check the governor shaft or linkages for binding, wear, or improper hookup. Check the governor spring for adequate

## SERVICE

### GOVERNOR ADJUSTMENT

With the engine stopped, loosen the screw holding the governor clamp on the governor lever. Rotate the clamp a direction that will force the throttle shaft open and allow the governor follower arm to rest on the governor spool. Push the governor lever connected to the throttle to the wide open throttle position. Hold the lever and clamp in this position while tightening the screw (diag. 7).

### GOVERNOR ADJUSTMENT PROCEDURE FOR SHORT BLOCK INSTALLATIONS

Short block installation on 3-5 h.p. vertical shaft engines built prior to 1977 may require the governor clamp (tinnerman style) to be repositioned to work properly. The clamp must be removed from the governor rod and turned to the same position as the original engine. Hook the solid link and spring to the governor lever and position the clamp on the governor rod. Follow the above governor adjustment procedure to complete the short block governor set-up. Units built after 1977 use the normal governor set up procedure. (diag. 8)

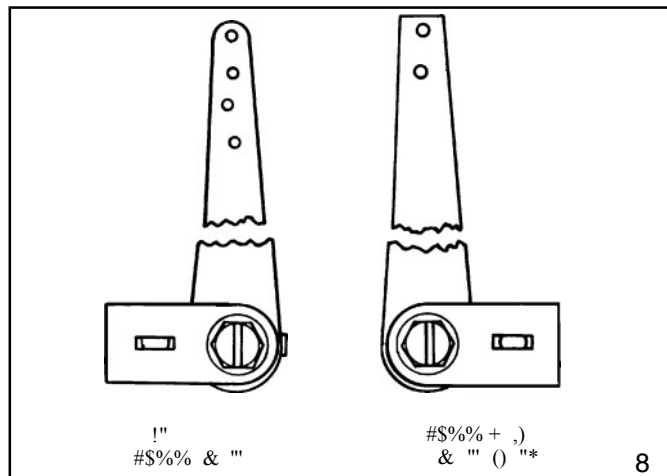
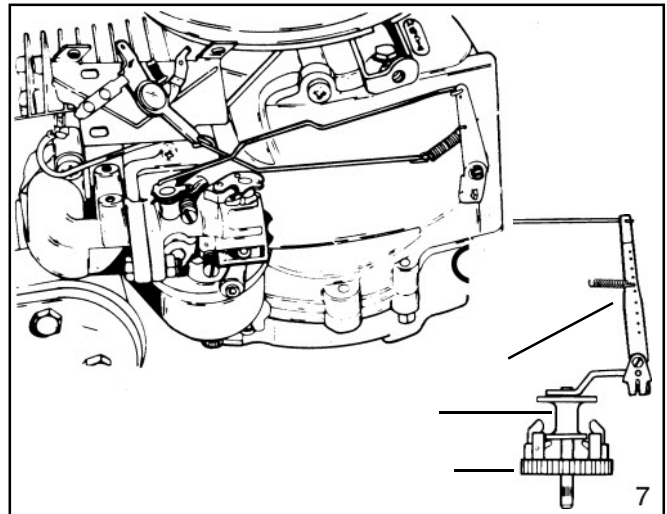

## GOVERNOR GEAR AND SHAFT SERVICE

After the cylinder cover is removed from the engine, the governor spool, gear, or governor shaft can be removed. On older style governor assemblies, the retaining ring must be removed to allow the spool or gear to slide off the shaft. governor shafts (3 - 6.75 model engines) use an upset to hold the governor spool on. If the gear requires replacement, the governor shaft will have to be removed.

### Governor Spool Replacement With Upset Style Governor Shaft

The spool can be replaced without removing the governor shaft. Grip the original spool in a vise and use a twisting and pulling motion on the flange until the spool is free.

Install the new spool by starting it on the shaft and then in the proper position. Place the spool on a solid surface and push on the flange until the spool seats. The governor weights must be in position under the spool after installation. (diag. 9)

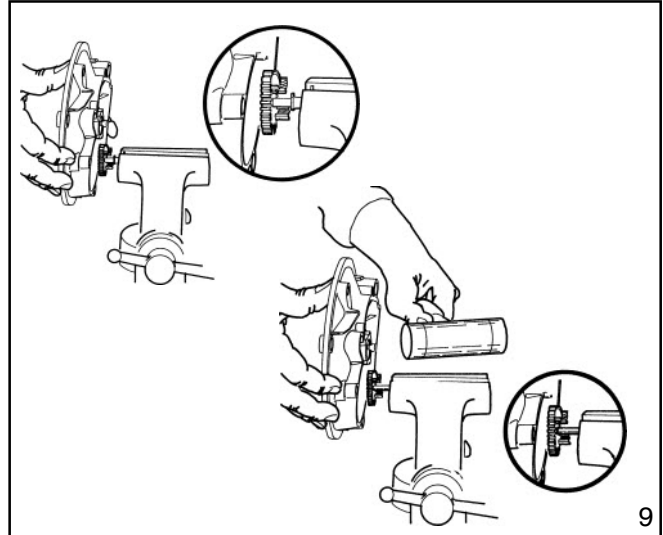

### Governor Gear or Shaft Replacement, Upset Style Governor Shaft

1. Grip the original spool in a vise and use a twisting and pulling motion on the flange until the spool is free.
2. Clamp the shaft in a vise and pound gently on the flange with a wooden or plastic mallet to remove the shaft.

**NOTE: DO NOT TWIST THE SHAFT WHEN REMOVING. THE SHAFT BOSS MAY BECOME ENLARGED, LEAVING THE NEW GOVERNOR SHAFT LOOSE AND CAUSING SEVERE DAMAGE.**

3. To install a new shaft, first assemble the gear and washer on the shaft. Start the shaft into the hole with a few taps from a soft faced hammer.

a shim, part # 670297 just becomes snug [.010 - .020 (.254 - .508 mm) clearance].

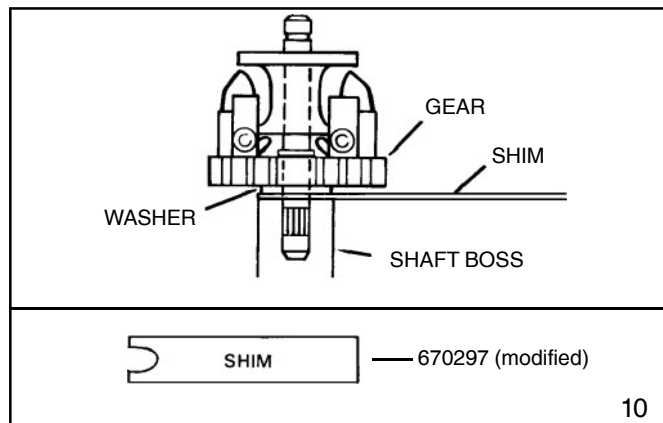

### Governor Shaft Replacement, Retaining Ring Style

1. Remove the retaining ring, spool, gear assembly, and washers.
2. Clamp the shaft in a vise and pound gently on the flange with a wooden or plastic mallet to remove the shaft.

**NOTE: DO NOT TWIST THE SHAFT WHEN REMOVING. THE SHAFT BOSS MAY BECOME ENLARGED AND THE NEW GOVERNOR SHAFT WILL BE LOOSE AND MOVE.**

3. Start the new shaft into the shaft boss by tapping with a soft faced hammer.
4. Refer to the chart at right for the proper shaft exposed length. Add a drop of red Loctite 271 and press the governor shaft to the proper depth using a press or a 11).
5. Reassemble the governor and install the retaining ring.

ENGINE MODEL	EXPOSED SHAFT LENGTH
ECH90 ECV100 H 30, 35 HS 40, 50 LAV 35 LEV (all) OHH (all) OVRM (all) TNT 100, 120 TVS (all)	Mounting flange to Top 1.319 - 1.334" (33.502 - 33.883 mm)
TVM (all) V 50, 60, 70 VH 50, 60, 70	Mounting flange to Top 1.581 - 1.596" (25.806 - 26.314 mm)
HH 100, 120 VH 100	Mounting flange to Top 1.016 - 1.036" (25.806 - 26.314 mm)
H 50, 60, 70 HH 60, 70 HHM80 HM 70, 80, 100	Mounting flange to Shoulder 1.283 - 1.293" (32.588 - 32.842 mm)

## SPEED CONTROLS AND LINKAGE

Many different types of speed controls and linkage are used for O.E.M. applications. Linkage attachment points are best recorded or marked prior to disassembly. This assures the correct placement during reassembly. On vertical engines the solid link is always connected from the outermost hole in the governor lever to the throttle in the carburetor. The link with the governor spring attached is connected between the control lever and the lower hole in the governor. Horizontal engines use one location (non-adjustable) speed control brackets. Most vertical engines use an adjustable speed control bracket mounted above the carburetor. The ignition ground out switch, idle R.P.M. and high speed R.P.M. adjustment screws are located on the speed control bracket. Some models use the idle R.P.M. adjustment on the carburetor.

Most vertical shaft engines must have the speed control bracket aligned when installing. To align the control bracket,

1. Loosen the two screws on the top of the panel.
2. Move the control lever to full wide open throttle position and install a wire or aligning pin through the hole in the top of the panel, the hole in the choke actuating lever, and the hole in the choke (diag. 12).
3. With the components aligned, tighten the two screws on the control panel.

The following pages illustrate common linkage attachment. Whenever the carburetor or the governor linkage is removed or replaced, the engine R.P.M.'s should also be system for the correct R.P.M. settings for the engine model and specification.

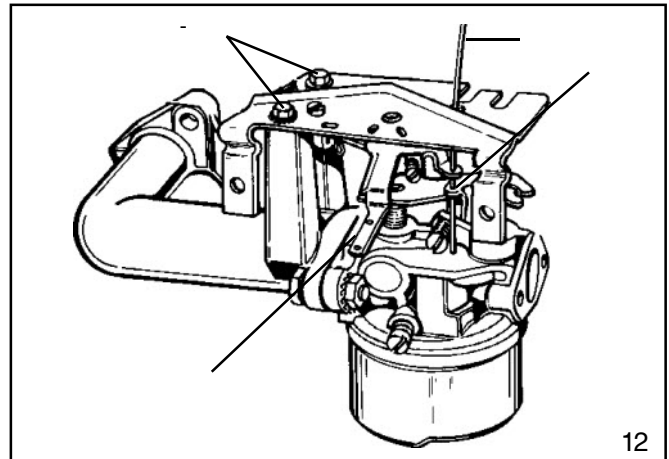

### SNAP IN "STYLE SPEED CONTROL"

This style of speed control is used on 3 - 6.75 model rotary mower engines and is adjusted by two bendable tabs. Use the speed adjustment tool (part # 670326) as illustrated in diag. 13 to adjust engine speed.

To adjust high speed, move the speed control lever to the high speed position and align the high speed pin holes.

Place the adjustment tool on the high speed tab and speed control lever to the low speed position, place the adjustment tool on the low speed tab and bend to either increase or decrease to the correct speed.

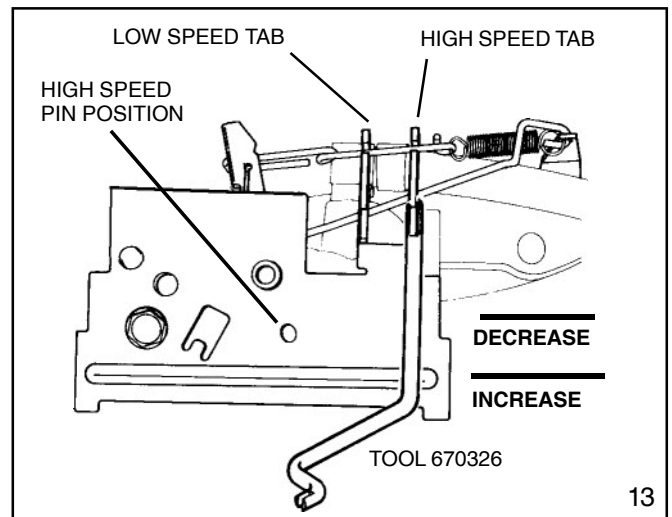

## ADJUSTING RPM ON MEDIUM FRAME VERTICAL SPEED CONTROL

This speed control is adjusted by aligning the slot in the speed control lever with the alignment hole on the mounting bracket. Place a pin through the two holes, place the equipment throttle control to the wide open position, the bowden cable end in the control as shown, and tighten the cable housing clamp. In this position, the gap of .040" - .070" (1.016 - 1.778 mm) should exist at the gap location as illustrated. This will assure that the carburetor will go into full choke when the control is placed in the start position.

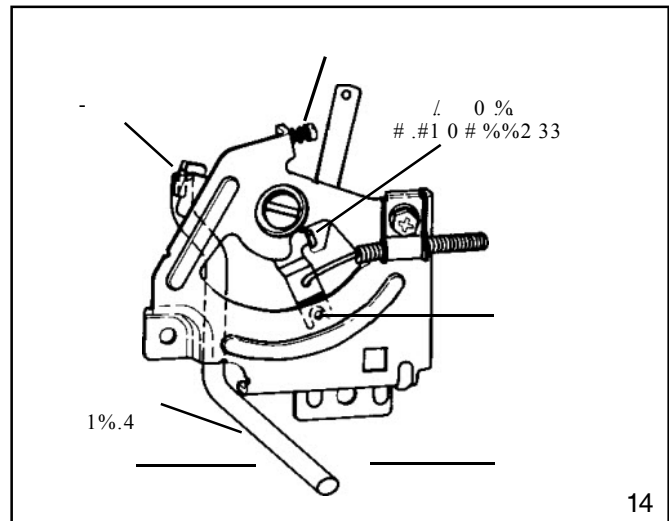

## ADJUSTING GOVERNED/NON-GOVERNED

With the engine running at its lowest speed, set the governed idle at the designated RPM by adjusting the governed idle screw or bending the idle tab. Next set the non-governed idle by pushing the bottom of the governor lever away from the control brackets so the throttle lever contacts the idle speed crack screw (on the carburetor). Hold the lever in this position and turn the crack screw to 600 RPM below the governed idle speed. This setting prevents the throttle plate from closing off when going from high speed RPM to low speed RPM. If improperly adjusted, the engine could experience an over lean condition.

The idle speed is adjusted by turning the idle speed screw clockwise to increase engine R.P.M. and counter-clockwise to decrease R.P.M. Use tool part # 670326 to adjust the onto the adjustment tab and bend the tab to the left (toward the spark plug end) to increase engine R.P.M. (diag. 14).

NOTE: Some engines use nylon bushings on the throttle and choke linkage hook-up points to extend the life of the linkage and to enhance the stability of the governor system. Make sure they are in good condition and in place.

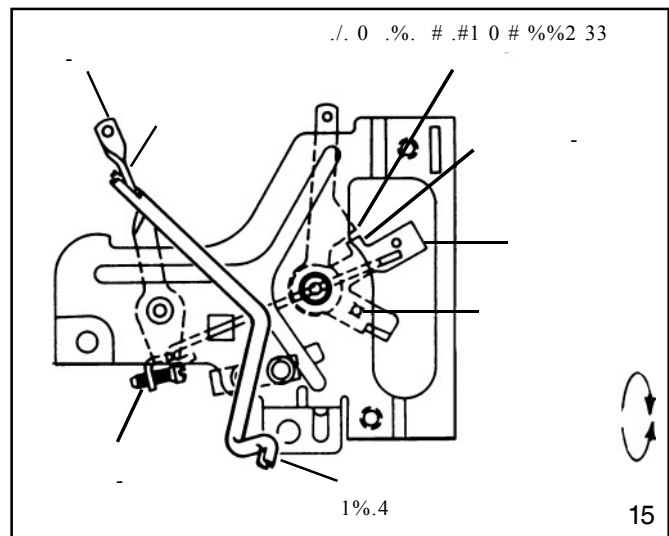

## ADJUSTING RPM ON MEDIUM FRAME VERTICAL (up/down speed control)

To adjust the high speed RPM on Medium Frame Vertical engines, move the control lever to the high speed position (align high speed pin holes in the speed control bracket). Place the slot on the straight end of tool (number 670326) onto the high speed adjustment tab as Rotate the bent end of the tool counterclockwise to increase RPM and clockwise to decrease RPM. (diag. 15).

# HORIZONTAL SHAFT ENGINES

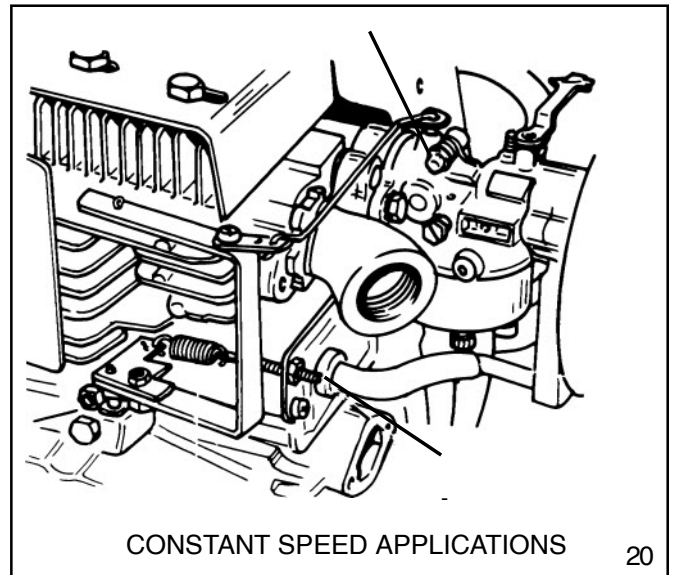
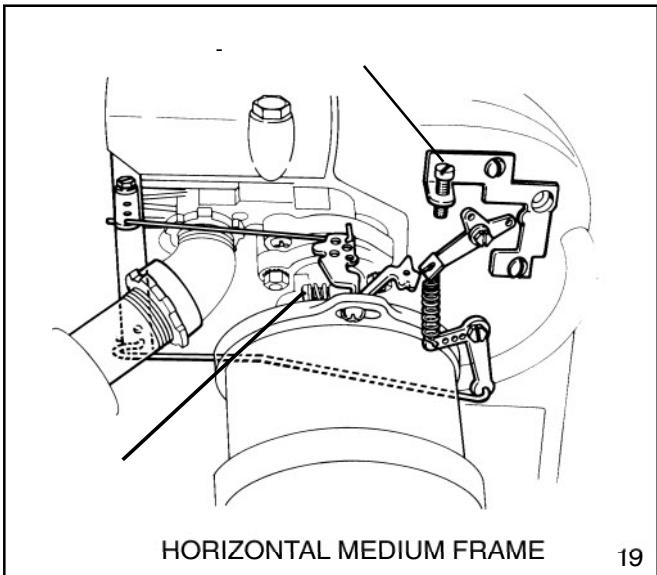
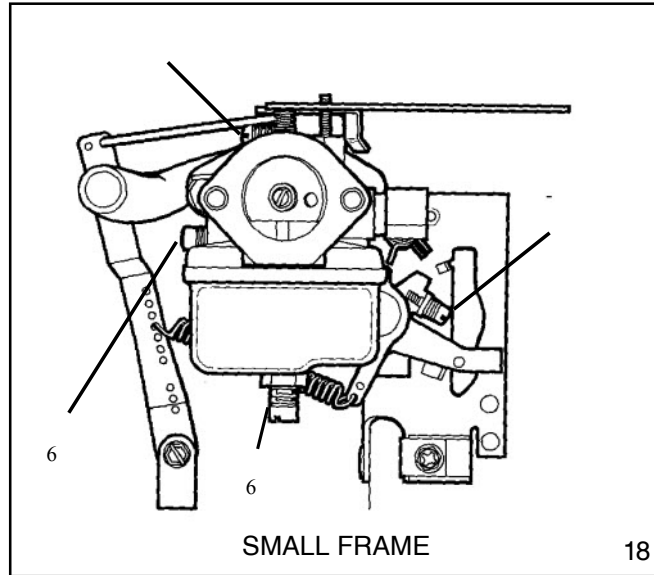
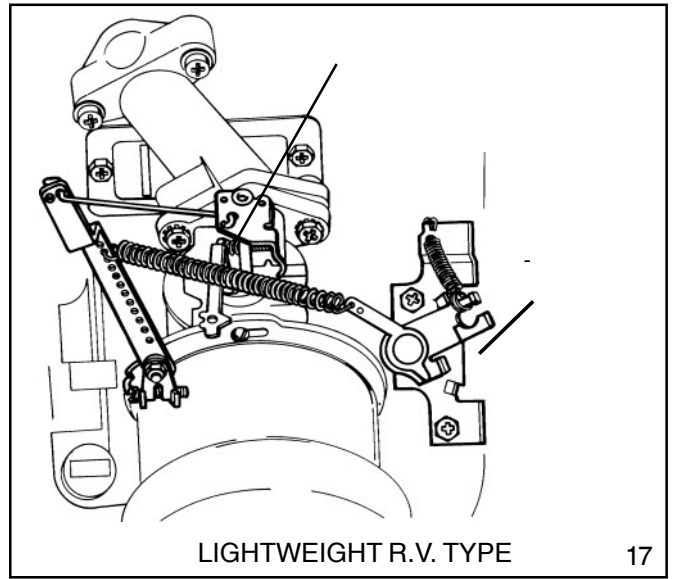
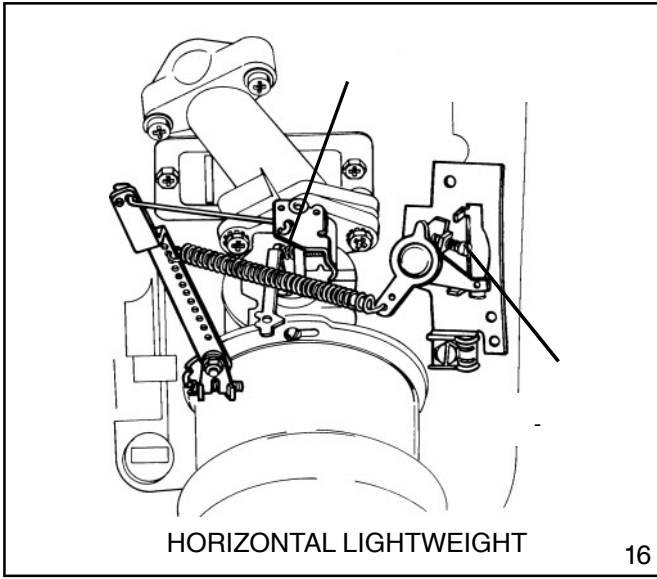



# HORIZONTAL SHAFT ENGINES (CONTINUED)

